

# Installation & Removal Instructions for B-LOC® Keyless Locking Devices

# B-LOC®

B-LOC Keyless Locking Devices provide a high capacity, zero-backlash shaft/hub or coupling connection by means of a mechanical interference fit. Referring to the series, please follow these Installation & Removal Instructions carefully to ensure proper performance of your B-LOC unit.

<b>B103</b> .....	<b>2</b>	<b>Split</b>	
<b>B106</b> .....	<b>2</b>	<b>Shrink Discs</b> .....	<b>11</b>
<b>B109</b> .....	<b>3</b>	<b>Half</b>	
<b>B112</b> .....	<b>4</b>	<b>Shrink Discs</b> .....	<b>12</b>
<b>B113</b> .....	<b>5</b>	<b>SD40</b> .....	<b>13</b>
<b>B115</b> .....	<b>6</b>	<b>BCH</b> .....	<b>14</b>
<b>B117</b> .....	<b>7</b>	<b>WK Rigid</b>	
<b>B400</b> .....	<b>8</b>	<b>Couplings</b> .....	<b>15</b>
<b>B800</b> .....	<b>9</b>		
<b>Shrink Discs</b> .....	<b>10</b>		

# Installation & Removal Instructions for B-LOC®

## Keyless Bushing Series B106 & B103

# B-LOC®

B-LOC Keyless Bushings provide a high capacity, zero-backlash shaft/hub or coupling connection by means of a mechanical interference fit. Please follow these **INSTALLATION AND REMOVAL INSTRUCTIONS** carefully to ensure proper performance of this B-LOC unit.

### ⓘ WARNING ⓘ

When installing or removing B-LOC products, always adhere to the following safety standards:

1. Be sure that the system is de-energized using proper lockout/tagout procedures.
2. Wear proper personal protective equipment.

### INSTALLATION (Refer to Figure 1)

B-LOC Series B103 and B106 Keyless Bushings are supplied lightly oiled and ready for installation. They are self-centering and fit straight-thru hub bores. Note that Series B103 units permit axial hub movement during installation. In contrast, the extended flange on Series B106 units results in an axially fixed hub position during assembly. When reinstalling a used unit, make sure that all slits are aligned. The frictional torque capacity of these devices is based on a coefficient of friction of 0.12 for lightly oiled screw, taper, shaft and bore contact areas.

Therefore, it is important **not** to use Molybdenum Disulfide (e.g., Molykote, Never-Seze or similar lubricants) in any Keyless Bushing installation.

1. Make sure that locking screw, taper, shaft and bore contact areas are clean and lightly oiled with a light machine oil and that all collar slits are aligned.
2. Loosen all locking screws by a minimum of four (4) turns and transfer at least three (3) screws into push-off threads in order to keep Parts 1 and 2 separated during assembly (see Figure 2).
3. After inserting Keyless Bushing into hub bore, relocate locking screws used for separating Parts 1 and 2.
4. Hand tighten locking screws and confirm that collar Item 1 is parallel and in full contact with face of part to be attached to shaft.
5. Use torque wrench and set it approximately 5% higher than specified tightening torque ( $M_a$ ). Tighten locking screws in either a clockwise or counterclockwise sequence (it is not necessary to tighten in a diametrically opposite pattern), using only 1/4 (i.e., 90°) turns for several passes until 1/4 turns can no longer be achieved.
6. Continue to apply overtorque for 1 to 2 more passes. This is required to compensate for a system-related relaxation of locking screws since tightening of a given screw will always relax adjacent screws. Without overtorquing, an infinite number of passes would be needed to reach specified tightening torque.
7. Reset torque wrench to specified torque ( $M_a$ ) and check all locking screws. No screw should turn at this point, otherwise repeat Steps 6 and 7.

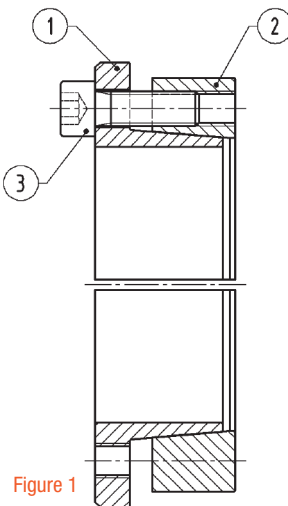

Figure 1

### INSTALLATION OF B-LOC® KEYLESS BUSHING OVER SHAFT KEYWAYS

The Keyless Bushing should be positioned so that slits in Keyless Bushing collars that contact the shaft are located approximately opposite the keyway. In addition, a locking screw should be centered directly over the keyway.

When tightening locking screws, it is important to follow the installation procedure outlined above, which specifies equal 1/4 turns of each locking screw. Failure to follow these instructions could result in excessive tightening of the screw over the keyway, possibly causing permanent deformation of the Keyless Bushing collars.

### REMOVAL (Refer to Figure 2)

**Prior to initiating the following removal procedure, check to ensure that no torque or thrust loads are acting on the Keyless Bushing, shaft or any mounted components.**

**IMPORTANT!** Make sure ends of locking screws used for removal are ground flat and are slightly chamfered to prevent damage to screw and collar threads during push-off.

1. Check to ensure that axial movement of collars - necessary for release of connection - is not restricted. Likewise, ensure that push-off threads are in good condition.
2. Relax all locking screws by approx. four (4) complete turns and transfer screws to all push-off threads located in flange of collar Item 1.
3. Release connection by evenly tightening all push-off screws (not exceeding 1/4 turns) in a diametrically opposite sequence.

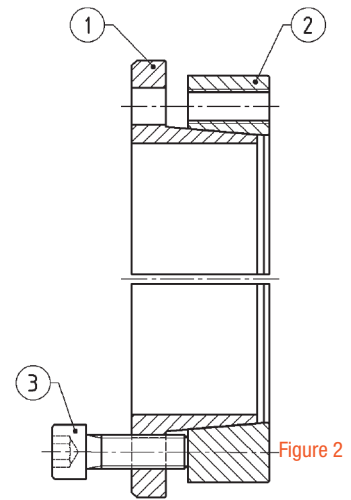

Figure 2

### Locking Screw Sizes and Specified Tightening Torque $M_a$

Metric Series	Inch Series	Tightening Torque $M_a$ (ft lb)		Screw Size	Hex Key Size (mm)
		B106	B103		
20 x 47 to 40 x 65	3/4 to 1-1/2	12	10	M6	5
45 x 75 to 65 x 95	1-5/8 to 2-9/16	30	25	M8	6
70 x 110 to 95 x 135	2-11/16 to 3-3/4	60	50	M10	8
100 x 145 to 120 x 165	3-15/16 to 4-3/4	105	90	M12	10
130 x 180 to 200 x 260	4-15/16 to 8	166	135	M14	12
220 x 285 to 260 x 325		257	219	M16	14
280 x 355 to 300 x 375		350	290	M18	14
320 x 405 to 340 x 425		500	420	M20	17
360 x 455 to 400 x 495		675	560	M22	17

- NOTE:**
1. It is not necessary to re-check tightening torque after equipment has been in operation.
  2. The torque capacity of these units can be increased by approximately 25% by thoroughly cleaning the shaft and Keyless Bushing bore of any lubricant. In applications subject to extreme corrosion, the slits in all collars should be sealed with a suitable caulking compound or equivalent. Likewise, push-off threads should be protected from corrosion.

B-LOC Keyless Bushings provide a high capacity, zero-backlash shaft/hub or coupling connection by means of a mechanical interference fit. Please follow these **INSTALLATION AND REMOVAL INSTRUCTIONS** carefully to ensure proper performance of this B-LOC unit.

### ⓘ WARNING ⓘ

When installing or removing B-LOC products, always adhere to the following safety standards:

1. Be sure that the system is de-energized using proper lockout/tagout procedures.
2. Wear proper personal protective equipment.

### INSTALLATION (Refer to Figure 1)

Series B109 Keyless Bushings are supplied lightly oiled and ready for installation. They are self-centering and fit straight-thru hub bores. Note that the extended flange on Series B109 units results in an axially fixed hub position during assembly. When reinstalling a used unit, make sure that all slits are aligned. The frictional torque capacity of these devices is based on a coefficient of friction of 0.12 for lightly oiled screw, taper, shaft and bore contact areas.

**Therefore, it is important not to use Molybdenum Disulfide (e.g., Molykote, Never-Seize or similar lubricants) in any Keyless Bushing installation.**

1. Make sure that locking screw, taper, shaft and bore contact areas are clean and lightly oiled with a light machine oil and that all collar slits are aligned.
2. Loosen all locking screws by a minimum of four (4) turns and transfer at least three (3) screws into push-off threads in order to keep Parts 1 and 2 separated during assembly (see Figure 2).
3. After inserting Keyless Bushing into hub bore, relocate locking screw(s) used for separating Parts 1 and 2.
4. Hand tighten locking screws and confirm that collar Item 1 is parallel and in full contact with face of part to be attached to shaft.
5. Use torque wrench and set it approximately 5% higher than specified tightening torque ( $M_a$ ). Tighten locking screws in either a clockwise or counterclockwise sequence (it is not necessary to tighten in a diametrically opposite pattern), using only 1/4 (i.e., 90°) turns for several passes until 1/4 turns can no longer be achieved.
6. Continue to apply overtorque for 1 to 2 more passes. This is required to compensate for a system-related relaxation of locking screws since tightening of a given screw will always relax adjacent screws. Without overtorquing, an infinite number of passes would be needed to reach specified tightening torque.
7. Reset torque wrench to specified torque ( $M_a$ ) and check all locking screws. No screw should turn at this point, otherwise repeat Steps 6 and 7.

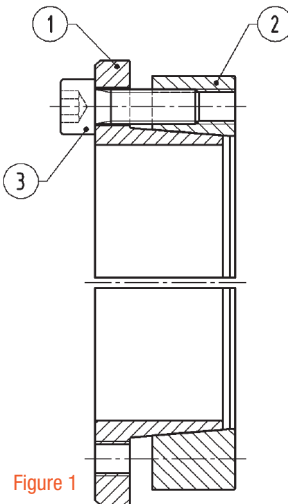

Figure 1

### INSTALLATION OF B-LOC® KEYLESS BUSHING OVER SHAFT KEYWAYS

The Keyless Bushing should be positioned so that slits in Keyless Bushing collars that contact the shaft are located approximately opposite the keyway. In addition, a locking screw should be centered directly over the keyway.

When tightening locking screws, it is important to follow the installation procedure outlined above, which specifies equal 1/4 turns of each locking screw. Failure to follow these instructions could result in excessive tightening of the screw over the keyway, possibly causing permanent deformation of the Keyless Bushing collars.

### REMOVAL (Refer to Figure 2)

**Prior to initiating the following removal procedure, check to ensure that no torque or thrust loads are acting on the Keyless Bushing, shaft or any mounted components.**

**IMPORTANT!** Make sure ends of locking screws used for removal are ground flat and are slightly chamfered to prevent damage to screw and collar threads during push-off.

1. Check to ensure that axial movement of collars - necessary for release of connection - is not restricted. Likewise, ensure that push-off threads are in good condition.
2. Relax all locking screws by approx. four (4) complete turns and transfer screws to all push-off threads located in flange of collar Item 1.
3. Release connection by evenly tightening all push-off screws (not exceeding 1/4 turns) in a diametrically opposite sequence.

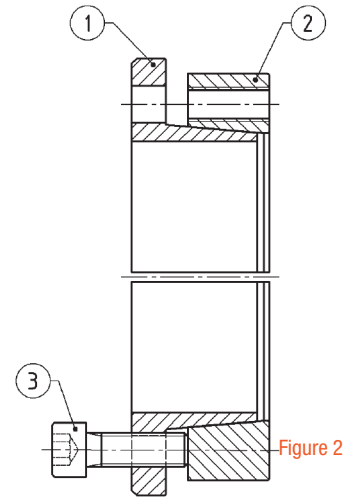

Figure 2

### Locking Screw Sizes and Specified Tightening Torque $M_a$

Metric Series	Inch Series	Tightening Torque $M_a$ (ft lb)	Screw Size	Hex Key Size (mm)
6mm	1/4	38	M4	3
8mm to 19mm	5/16 to 3/4	42.5	M4	3
20mm to 35mm	7/8 to 1-3/8	87	M5	4

- NOTE:**
1. It is not necessary to re-check tightening torque after equipment has been in operation.
  2. The torque capacity of these units can be increased by approximately 25% by thoroughly cleaning the shaft and Keyless Bushing bore of any lubricant. In applications subject to extreme corrosion, the slits in all collars should be sealed with a suitable caulking compound or equivalent. Likewise, push-off threads should be protected from corrosion.

# Installation & Removal Instructions for B-LOC®

## Keyless Bushing Series B112

# B-LOC®

B-LOC Keyless Bushings provide a high capacity, zero-backlash shaft/hub or coupling connection by means of a mechanical interference fit. Please follow these **INSTALLATION AND REMOVAL INSTRUCTIONS** carefully to ensure proper performance of this B-LOC unit.

### ⓘ WARNING ⓘ

When installing or removing B-LOC products, always adhere to the following safety standards:

1. Be sure that the system is de-energized using proper lockout/tagout procedures.
2. Wear proper personal protective equipment.

### INSTALLATION (Refer to Figure 1)

B-LOC Keyless Bushings are supplied lightly oiled and ready for installation. When reinstalling a used unit, make sure that all slits are aligned and that front and rear clamp collars are not reversed (when assembled correctly there are no holes or threads behind taps in clamp collar Item 1, and no threads behind taps in center collar Item 3). The frictional torque capacity of these devices is based on a coefficient of friction of 0.12 for lightly oiled screw, taper, shaft and bore contact areas.

Therefore, it is important **not** to use Molybdenum Disulfide (e.g., Molykote, Never-Seize or similar lubricants) in any Keyless Bushing installation.

1. Make sure that locking screw, taper, shaft and bore contact areas are clean and lightly oiled with a light machine oil and that all collar slits are aligned.
2. Loosen all locking screws by a minimum of four (4) turns and transfer at least two (2) screws to push-off threads in clamp collar Item 1 to disengage this part from center collar Item 3. Similarly, transfer at least two (2) screws to push-off threads in center collar Item 3 to disengage this part from clamp collar Item 2 (see Figure 2).

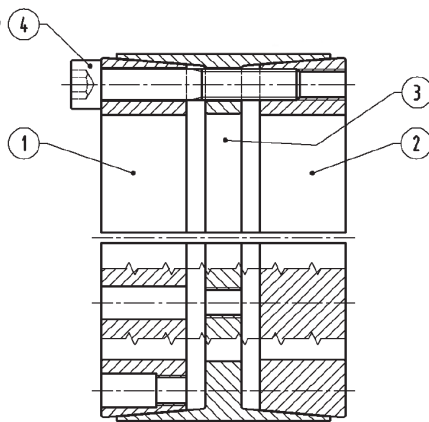

Figure 1

3. Completed assembly can now be placed on shaft and inserted into hub bore by pushing against face of collar Item 1 and heads of locking screws threaded into collar Item 2. This ensures collar Item 2 is not engaged at tapers during this phase.
4. After placement of Keyless Bushing, relocate locking screws used for separation of collars.
5. Hand tighten connection and confirm that clamp collar Item 1 is parallel with face of part to be attached to shaft and/or with the front facing edge of center collar Item 3.
6. Use torque wrench and set it approximately 5% higher than specified tightening torque ( $M_a$ ). Tighten locking screws in either a clockwise or counterclockwise sequence (it is not necessary to tighten in a diametrically opposite pattern), using only 1/4 (i.e., 90°) turns for several passes until 1/4 turns can no longer be achieved.
7. Continue to apply overtorque for 1 to 2 more passes. This is required to compensate for a system-related relaxation of locking screws since tightening of a given screw will always relax adjacent screws. Without overtorquing, an infinite number of passes would be needed to reach specified tightening torque.
8. Reset torque wrench to specified torque ( $M_a$ ) and check all locking screws. No screw should turn at this point, otherwise repeat Steps 7 and 8.

**NOTE:** 1. It is not necessary to re-check tightening torque after equipment has been in operation.

2. In installations subjected to extreme corrosion, the slits in clamp collars Item 1 and Item 2, as well as in center collars, should be sealed with a suitable caulking compound or equivalent. Likewise, push-off threads should also be protected from corrosion.

### INSTALLATION OF B-LOC® KEYLESS BUSHING OVER SHAFT KEYWAYS

The Keyless Bushing should be positioned so that slits in Keyless Bushing collars that contact the shaft are located approximately opposite the keyway. In addition, a locking screw should be centered directly over the keyway.

When tightening locking screws, it is important to follow the installation procedure outlined above, which specifies equal 1/4 turns of each locking screw. Failure to follow these instructions could result in excessive tightening of the screw over the keyway, possibly causing permanent deformation of the Keyless Bushing collars.

### REMOVAL (Refer to Figure 2)

**Prior to initiating the following removal procedure, check to ensure that no torque or thrust loads are acting on the Keyless Bushing, shaft or any mounted components.**

**IMPORTANT!** Make sure ends of locking screws used for removal are ground flat and are slightly chamfered to prevent damage to screw and collar threads during push-off.

1. Check to ensure that axial movement of collars - necessary for release of connection - is not restricted. Likewise, ensure that push-off threads are in good condition.
2. Remove all locking screws. Transfer required number of screws into all push-off threads of clamp collar Item 1 (see Figure 2).

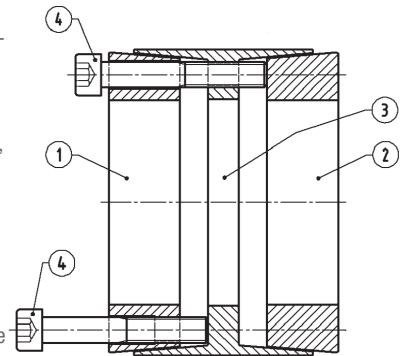

Figure 2

3. Release collar Item 1 by progressively tightening all push-off screws. Typically, the push-off screws appear to be completely tight after just one pass of tightening without any noticeable separation of clamp collars. Although it seems that the screws cannot be tightened further, several more rounds of torquing in either a clockwise or counterclockwise sequence will increase the push-off force in the system and ultimately release part of the front collar.

Afterwards, only the screws which are still tight should be tightened further until complete dismounting is achieved. Remove clamp collar Item 1.

4. Transfer locking screws used for dismounting of clamp collar Item 1 into all push-off threads in center collar Item 3 (see Figure 2). Release clamp collar Item 2 by repeating procedures outlined in Step 3.

### Locking Screw Sizes and Specified Tightening Torque $M_a$

Metric Series	Inch Series	Tightening Torque $M_a$ (ft lb)	Screw Size	Hex Key Size (mm)
25 x 55 to 35 x 60	1 to 1-7/16	12	M6	5
40 x 75 to 65 x 95	1-1/2 to 2-9/16	30	M8	6
70 x 110 to 90 x 130	2-5/8 to 3-5/8	60	M10	8
100 x 145 to 120 x 165	3-3/4 to 4-3/4	105	M12	10
130 x 180 to 160 x 210	4-15/16 to 6	166	M14	12
170 x 225 to 260 x 325	6-7/16 to 8	257	M16	14
280 x 355 to 340 x 425		500	M20	17
360 x 455 to 600 x 695		675	M22	17

# Installation & Removal Instructions for B-LOC®

## Keyless Bushing Series B113

# B-LOC®

B-LOC Keyless Bushings provide a high capacity, zero-backlash shaft/hub or coupling connection by means of a mechanical interference fit. Please follow these **INSTALLATION AND REMOVAL INSTRUCTIONS** carefully to ensure proper performance of this B-LOC unit.

### ⓘ WARNING ⓘ

When installing or removing B-LOC products, always adhere to the following safety standards:

1. Be sure that the system is de-energized using proper lockout/tagout procedures.
2. Wear proper personal protective equipment.

### INSTALLATION (Refer to Figure 1)

B-LOC Keyless Bushings are supplied lightly oiled and ready for installation. When reinstalling a used unit, make sure that all slits are aligned and that front and rear clamp collars are not reversed (when assembled correctly there are no holes or threads behind taps in clamp collar Item 1, and no threads behind taps in center collar Item 3). The frictional torque capacity of these devices is based on a coefficient of friction of 0.12 for lightly oiled screw, taper, shaft and bore contact areas.

Therefore, it is important not to use Molybdenum Disulfide (e.g., Molykote, Never-Seize or similar lubricants) in any Keyless Bushing installation.

1. Make sure that locking screw, taper, shaft and bore contact areas are clean and lightly oiled with a light machine oil and that all collar slits are aligned.
2. Loosen all locking screws by a minimum of four (4) turns and transfer at least three (3) screws to equally spaced push-off threads in clamp collar Item 1 to disengage this part from center collar Item 3. To disengage collar Item 2 from taper interface, lightly tap heads of three (3) equally spaced locking screws that have been engaged at least four (4) turns into collar Item 2 (see Figure 1).
3. Completed assembly can now be placed on shaft and inserted into hub bore by pushing against face of collar Item 1 and heads of locking screws threaded into collar item 2. This ensures collar Item 2 is not engaged at tapers during this phase.
4. After placement of Keyless Bushing, relocate locking screws used for separation of collars.
5. Hand tighten connection and confirm that clamp collar Item 1 is parallel with face of part to be attached to shaft and/or with the front facing edge of center collar Item 3.
6. Use torque wrench and set it approximately 5% higher than specified tightening torque ( $M_a$ ). Tighten screws in either a clockwise or counterclockwise sequence (it is not necessary to tighten in a diametrically opposite pattern), using only 1/4 (i.e., 90°) turns for several passes until 1/4 turns can no longer be achieved.
7. Continue to apply overtorque for 1 to 2 more passes. This is required to compensate for a system-related relaxation of locking screws since tightening of a given screw will always relax adjacent screws. Without overtorquing, an infinite number of passes would be needed to reach specified tightening torque.
8. Reset torque wrench to specified torque ( $M_a$ ) and check all locking screws. No screw should turn at this point, otherwise repeat Steps 7 and 8.

- NOTE:**
1. It is not necessary to re-check tightening torque after equipment has been in operation.
  2. In installations subjected to extreme corrosion, the slits in clamp collars Item 1 and Item 2, as well as in center collars, should be sealed with a suitable caulking compound or equivalent. Likewise, push-off threads should also be protected from corrosion.

### INSTALLATION OF B-LOC® KEYLESS BUSHING OVER SHAFT KEYWAYS

The Keyless Bushing should be positioned so that slits in Keyless Bushing collars that contact the shaft are located approximately opposite the keyway. In addition, a locking screw should be centered directly over the keyway.

When tightening locking screws, it is important to follow the installation procedure outlined above, which specifies equal 1/4 turns of each locking screw. Failure to follow these instructions could result in excessive tightening of the screw over the keyway, possibly causing permanent deformation of the Keyless Bushing collars.

### REMOVAL (Refer to Figure 2)

**Prior to initiating the following removal procedure, check to ensure that no torque or thrust loads are acting on the Keyless Bushing, shaft or any mounted components.**

**IMPORTANT!** Make sure ends of locking screws used for removal are ground flat and are slightly chamfered to prevent damage to screw and collar threads during push-off.

1. Check to ensure that axial movement of collars - necessary for release of connection - is not restricted. Likewise, ensure that push-off threads are in good condition.

2. Remove all locking screws. Transfer required number of screws into all push-off threads of clamp collar Item 1 (see Figure 2).

3. Release collar Item 1 by progressively tightening all push-off screws. Typically, the push-off screws appear to be completely tight after just one pass of tightening without any noticeable separation of clamp collars. Although it seems that the screws cannot be tightened further, several more rounds of torquing in either a clockwise or counterclockwise sequence will increase the push-off force in the system and ultimately release part of the front collar. Afterwards, only the screws which are still tight should be tightened further until complete dismounting is achieved. Remove collar Item 1 and cover plate Item 4 (cover plate Item 4 is supplied with multiple smaller threads at the collar face for this purpose).

4. Transfer locking screws used for dismounting of clamp collar Item 1 into all push-off threads in center collar Item 3 (see Figure 2). Release clamp collar Item 2 by repeating procedures outlined in Step 3.

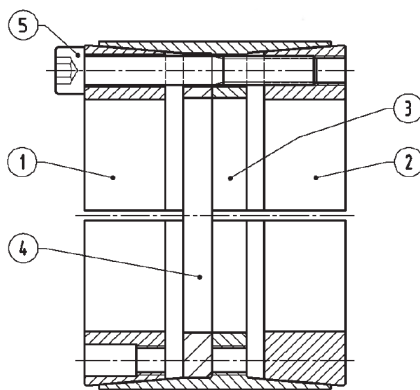

Figure 1

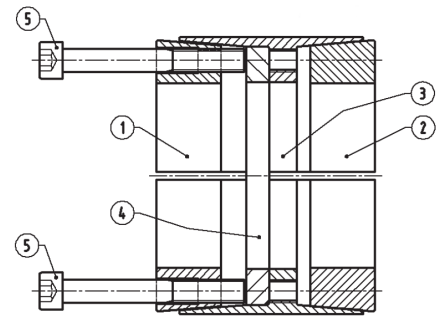

Figure 2

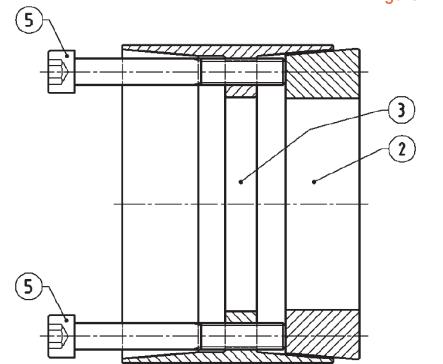

Figure 3

### Locking Screw Sizes and Specified Tightening Torque

Metric Series	$M_a$		
	Tightening Torque $M_a$ (ft lb)	Screw Size Din 912 Grade 12.9	Hex Key Size (mm)
180 x 285 to 220 x 325	675	M22 x 180	17
240 x 355 to 300 x 425	870	M24 x 180	19
320 x 455 to 560 x 695	1300	M27 x 220	19

B-LOC Keyless Bushings provide a high capacity, zero-backlash shaft/hub or coupling connection by means of a mechanical interference fit. Please follow these **INSTALLATION AND REMOVAL INSTRUCTIONS** carefully to ensure proper performance of this B-LOC unit.

### ⓘ WARNING ⓘ

When installing or removing B-LOC products, always adhere to the following safety standards:

1. Be sure that the system is de-energized using proper lockout/tagout procedures.
2. Wear proper personal protective equipment.

### INSTALLATION (Refer to Figure 1)

B-LOC Keyless Bushings are supplied lightly oiled and ready for installation. When reinstalling a used unit, make sure that all slits are aligned and that front and rear clamp collars are not reversed (when assembled correctly there are no holes or threads behind taps in clamp collar Item 1, and no threads behind taps in center collar Item 3). The frictional torque capacity of these devices is based on a coefficient of friction of 0.12 for lightly oiled screw, taper, shaft and bore contact areas.

Therefore, it is important not to use Molybdenum Disulfide (e.g., Molykote, Never-Seize or similar lubricants) in any Keyless Bushing installation.

1. Make sure that locking screw, taper, shaft and bore contact areas are clean and lightly oiled and that all collar slits are aligned.
2. Loosen all locking screws by a minimum of four (4) turns and transfer at least two (2) screws to push-off threads in clamp collar Item 1 to disengage this part from center collar Item 3. Similarly, transfer at least two (2) screws to push-off threads in center collar Item 3 to disengage this part from clamp collar Item 2 (see Figure 2).
3. Completed assembly can now be placed on shaft and inserted into hub bore by pushing against face of collar Item 1 and heads of locking screws threaded into collar item 2. This ensures collar Item 2 is not engaged at tapers during this phase.
4. After placement of Keyless Bushing, relocate locking screws used for separation of collars.
5. Hand tighten connection and confirm that clamp collar Item 1 is parallel with face of part to be attached to shaft and/or with the front facing edge of center collar Item 3.
6. Use torque wrench and set it approximately 5% higher than specified tightening torque  $M_a$ . Tighten locking screws in either a clockwise or counterclockwise sequence (it is not necessary to tighten in a diametrically opposite pattern), using only 1/4 (i.e., 90°) turns for several passes until 1/4 turns can no longer be achieved.
7. Continue to apply overtorque for 1 to 2 more passes. This is required to compensate for a system-related relaxation of locking screws since tightening of a given screw will always relax adjacent screws. Without overtorquing, an infinite number of passes would be needed to reach specified tightening torque.
8. Reset torque wrench to specified torque ( $M_a$ ) and check all locking screws. No screw should turn at this point, otherwise repeat Steps 7 and 8.

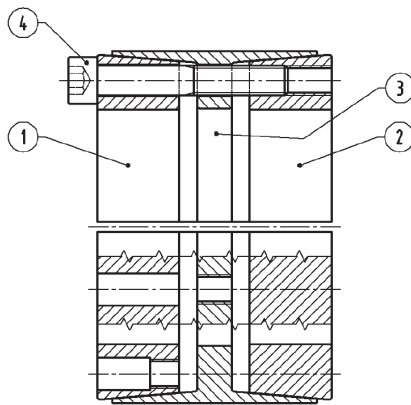

Figure 1

- NOTE:**
1. It is not necessary to re-check tightening torque after equipment has been in operation.
  2. In installations subjected to extreme corrosion, the slits in clamp collars Item 1 and Item 2, as well as in center collars, should be sealed with a suitable caulking compound or equivalent. Likewise, push-off threads should also be protected from corrosion.

### INSTALLATION OF B-LOC® KEYLESS BUSHING OVER SHAFT KEYWAYS

The Keyless Bushing should be positioned so that slits in Keyless Bushing collars that contact the shaft are located approximately opposite the keyway. In addition, a locking screw should be centered directly over the keyway.

When tightening locking screws, it is important to follow the installation procedure outlined above, which specifies equal 1/4 turns of each locking screw. Failure to follow these instructions could result in excessive tightening of the screw over the keyway, possibly causing permanent deformation of the Keyless Bushing collars.

### REMOVAL (Refer to Figure 2)

**Prior to initiating the following removal procedure, check to ensure that no torque or thrust loads are acting on the Keyless Bushing, shaft or any mounted components.**

**IMPORTANT!** Make sure ends of locking screws used for removal are ground flat and are slightly chamfered to prevent damage to screw and collar threads during push-off.

1. Check to ensure that axial movement of clamp collars - necessary for release of connection - is not restricted. Likewise, ensure that push-off threads are in good condition.
2. Remove all locking screws. Transfer required number of screws into all push-off threads of clamp collar Item 1 (see Figure 2).
3. Release collar Item 1 by progressively tightening all push-off screws. Typically, the push-off screws appear to be completely tight after just one pass of tightening without any noticeable separation of clamp collars. Although it seems that the screws cannot be tightened further, several more rounds of torquing in either a clockwise or counterclockwise sequence will increase the push-off force in the system and ultimately release part of the front collar. Afterwards, only the screws which are still tight should be tightened further until complete dismounting is achieved. Remove clamp collar Item 1.
4. Transfer locking screws used for dismounting of clamp collar Item 1 into all push-off threads in center collar Item 3 (see Figure 2). Release clamp collar Item 2 by repeating procedures outlined in Step 3.

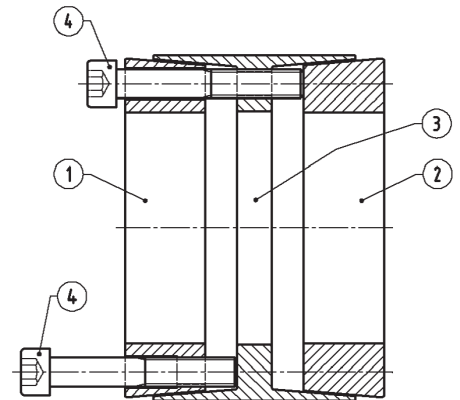

Figure 2

### Locking Screw Sizes and Specified Tightening Torque $M_a$

Metric Series	Inch Series	Tightening Torque $M_a$ (ft lb)	Screw Size	Hex Key Size (mm)
70 x 110 to 90 x 130	2-3/4 to 3-1/2	60	M10	8
100 x 145 to 160 x 210	3-15/16 to 6	105	M12	10
170 x 225 to 200 x 260	6-7/16 to 8	166	M14	12
220 x 285 to 260 x 325		257	M16	14
280 x 355 to 340 x 425		500	M20	17
360 x 455 to 600 x 695		675	M22	17

B-LOC Keyless Bushings provide a high capacity, zero-backlash shaft/hub or coupling connection by means of a mechanical interference fit. Please follow these **INSTALLATION AND REMOVAL INSTRUCTIONS** carefully to ensure proper performance of this B-LOC unit.

### ⓘ WARNING ⓘ

When installing or removing B-LOC products, always adhere to the following safety standards:

1. Be sure that the system is de-energized using proper lockout/tagout procedures.
2. Wear proper personal protective equipment.

### INSTALLATION (Refer to Figure 1)

B-LOC Keyless Bushings are supplied lightly oiled and ready for installation. They are self-centering and fit straight-thru hub bores. The extended flange on Series B117 results in an axially fixed hub position during assembly. When reinstalling a used unit, make sure that all slits are aligned. The frictional torque capacity of these devices is based on a coefficient of friction of 0.12 for lightly oiled screw, taper, shaft and bore contact areas.

Therefore, it is important **not** to use Molybdenum Disulfide (e.g., Molykote, Never-Seeze or similar lubricants) in any Keyless Bushing installation.

1. Make sure that locking screws, taper, shaft and bore contact areas are clean and lightly oiled with a light machine oil and that all collar slits are aligned.
2. Loosen all locking screws by a minimum of two (2) turns and transfer at least two (2) larger screws (item 4) into push-off threads in the collar (item 1) in order to keep tapers of Parts 1, 2 and 3 disengaged during assembly (see Figure 1).
3. After inserting Keyless Bushing into hub bore, relocate locking screws used for separating Parts 1, 2 and 3.

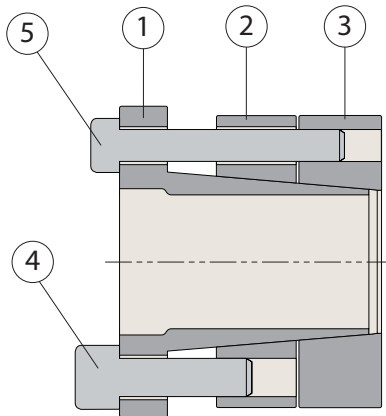

Figure 1

4. Hand tighten all locking screws and confirm that flanged collar (item 1) is parallel and in full contact with face of part to be attached to shaft.
5. Use a torque wrench and set to approximately 5% higher than specified tightening torque  $M_a$  for large screws (item 4). Tighten large locking screws in a clockwise or counterclockwise sequence (it is not necessary to tighten in a diametrically opposite pattern), using only 1/4 (i.e., 90°) turns for several passes until 1/4 turns can no longer be achieved.
6. Continue to apply overtorque for 1 to 2 more passes. This is required to compensate for a system-related relaxation of locking screws since tightening of a given screw will always relax adjacent screws. Without overtorquing, an infinite number of passes would be needed to reach specified tightening torque.
7. Repeat steps 5 and 6 for smaller locking screws (item 5), but setting 5% higher of specified tightening torque  $M_a$  for the smaller screws.
8. Reset torque wrench to specified torque ( $M_a$ ) and check all large locking screws and then reset torque wrench  $M_a$  and check all small locking screws. No screw should turn at this point, otherwise repeat Steps 6, 7 and 8.

- NOTE:**
1. It is not necessary to re-check tightening torque after equipment has been in operation.
  2. The torque capacity of these units can be increased by approximately 25% by thoroughly cleaning the shaft and Keyless Bushing bore of any lubricant. In applications subject to extreme corrosion, the slits in all collars should be sealed with a suitable caulking compound or equivalent. Likewise, push-off threads should be protected from corrosion.

### INSTALLATION OF B-LOC® KEYLESS BUSHING OVER SHAFT KEYWAYS

The Keyless Bushing should be positioned so that slits in Keyless Bushing collars that contact the shaft are located approximately opposite the keyway. In addition, a locking screw should be centered directly over the keyway.

When tightening locking screws, it is important to follow the installation procedure outlined above, which specifies equal 1/4 turns of each locking screw. Failure to follow these instructions could result in excessive tightening of the screw over the keyway, possibly causing permanent deformation of the Keyless Bushing collars.

### REMOVAL (Refer to Figure 2)

**Prior to initiating the following removal procedure, check to ensure that no torque or thrust loads are acting on the Keyless Bushing, shaft or any mounted components.**

**IMPORTANT!** Make sure ends of locking screws used for removal are ground flat and are slightly chamfered to prevent damage to screw and collar threads during push-off.

1. Check to ensure that axial movement of collars — necessary for release of connection — is not restricted. Likewise, ensure that push-off threads are in good condition.
2. Remove all locking screws (items 4 & 5) and transfer shorter screws (item 4) to all push-off threads located in flange of collar (item 1).
3. Release collar (item 2) by evenly tightening all push-off screws (not exceeding 1/4 turns) in a diametrically opposite sequence.
4. Release collar (item 3) by re-tightening all push-off screws.

### Locking Screw Sizes and Specified Tightening Torque $M_a$

Metric Series	Locking Screws			
	Size 1		Size 2	
	Size	Tightening Torque $M_a$ (Nm)	Size	Tightening Torque $M_a$ (Nm)
180 x 250 to 260 x 330	M20	678	M16	348
280 x 365 to 600 x 685	M24	1180	M20	678

B-LOC Keyless Bushings provide a high capacity, zero-backlash shaft/hub or coupling connection by means of a mechanical interference fit. Please follow these **INSTALLATION AND REMOVAL INSTRUCTIONS** carefully to ensure proper performance of this B-LOC unit.

### ⓘ WARNING ⓘ

When installing or removing B-LOC products, always adhere to the following safety standards:

1. Be sure that the system is de-energized using proper lockout/tagout procedures.
2. Wear proper personal protective equipment.

### INSTALLATION (Refer to Figure 1)

B-LOC Keyless Bushings are supplied lightly oiled and ready for installation. The frictional torque capacity of these devices is based on a coefficient of friction of 0.12 for lightly oiled screw, taper, shaft and bore contact areas.

Therefore, it is important **not** to use Molybdenum Disulfide (e.g., Molykote, Never-Seize or similar lubricants) in any Keyless Bushing installation.

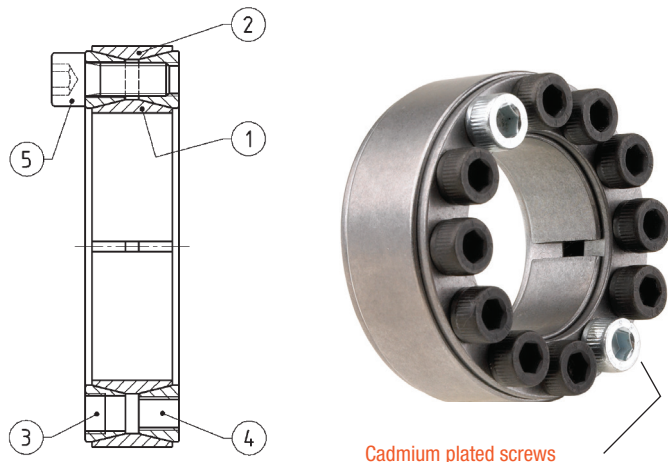

Figure 1

1. Make sure that locking screw, taper, shaft and bore contact areas are clean and lightly oiled with a light machine oil.
2. Insert Keyless Bushing into hub counterbore prior to shaft installation.
3. After confirming correct hub position, hand-tighten three (3) or four (4) equally spaced locking screws until initial contact with shaft and hub bore is established.
4. Use torque wrench and set it approximately 5% higher than specified tightening torque ( $M_a$ ). Tighten locking screws in either a clockwise or counterclockwise sequence (it is not necessary to tighten in a diametrically opposite pattern), using only 1/4 (i.e., 90°) turns for several passes until 1/4 turns can no longer be achieved.
5. Continue to apply overtorque for 1 to 2 more passes. This is required to compensate for a system-related relaxation of locking screws since tightening of a given screw will always relax adjacent screws. Without overtorquing, an infinite number of passes would be needed to reach specified tightening torque.
6. Reset torque wrench to specified torque ( $M_a$ ) and check all locking screws. No screw should turn at this point, otherwise repeat Steps 5 and 6.

- NOTE:**
1. It is not necessary to re-check tightening torque after equipment has been in operation.
  2. In applications subject to extreme corrosion, the slits in all collars can be sealed with a suitable caulking compound or equivalent.

### INSTALLATION OF B-LOC® KEYLESS BUSHING OVER SHAFT KEYWAYS

The Keyless Bushing should be positioned so that slits in Keyless Bushing collars that contact the shaft are located approximately opposite the keyway. In addition, a locking screw should be centered directly over the keyway.

When tightening locking screws, it is important to follow the installation procedure outlined above, which specifies equal 1/4 turns of each locking screw. Failure to follow these instructions could result in excessive tightening of the screw over the keyway, possibly causing permanent deformation of the Keyless Bushing collars.

### REMOVAL (Refer to Figure 2)

**Prior to initiating the following removal procedure, check to ensure that no torque or thrust loads are acting on the Keyless Bushing, shaft or any mounted components.**

1. Loosen locking screws in several stages by using approx. 1/4 turns, following either a clockwise or counterclockwise sequence.

**NOTE:** B-LOC® Series B400 Keyless Bushings feature self-releasing tapers, meaning collars should release during Step 1. However, if for some reason the thrust collars jam, a light tap on three (3) equally spaced heads of loosened locking screws will positively release the connection.

2. Hub and Keyless Bushing are normally removed together. Removal of Keyless Bushing only from deep counterbores is accomplished by inserting pull-off screws (not provided) into threads located under plated locking screws. These threads are NOT to be used for high pulling forces, as thrust collar is only partially threaded.

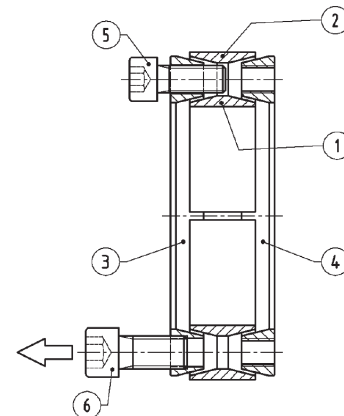

Figure 2

### Locking Screw Sizes and Specified Tightening Torque $M_a$

Metric Series	Inch Series	Tightening Torque $M_a$ (ft lb)	Screw Size	Hex Key Size (mm)	Pull-off Thread dB
20 x 47 to 40 x 65	3/4 to 1-1/2	11	M6	5	M8
42 x 75 to 65 x 95	1-5/8 to 2-9/16	26	M8	6	M10
70 x 110 to 95 x 135	2-5/8 to 3-3/4	51	M10	8	M12
100 x 145 to 160 x 210	3-7/8 to 6	91	M12	10	M14
170 x 225 to 200 x 260	6-7/16 to 8	138	M14	12	M16
220 x 285 to 260 x 325		214	M16	14	M20
280 x 355 to 300 x 375		293	M18	14	M22
320 x 405 to 340 x 425		420	M20	17	M24
360 x 455 to 420 x 515		565	M22	17	M27
440 x 545 to 1000 x 1110		725	M24	19	M30

dB = pull-off thread, located only under cadmium plated screws of front thrust collar

# Installation & Removal Instructions for B-LOC®

## Keyless Bushing Series B800

# B-LOC®

B-LOC Keyless Bushings provide a high capacity, zero-backlash shaft/hub or coupling connection by means of a mechanical interference fit. Please follow these **INSTALLATION AND REMOVAL INSTRUCTIONS** carefully to ensure proper performance of this B-LOC unit.

### ⓘ WARNING ⓘ

When installing or removing B-LOC products, always adhere to the following safety standards:

1. Be sure that the system is de-energized using proper lockout/tagout procedures.
2. Wear proper personal protective equipment.

### INSTALLATION (Refer to Figure 1)

B-LOC Keyless Bushings are supplied lightly oiled and ready for installation. The frictional torque capacity of these devices is based on a coefficient of friction of 0.12 for lightly oiled screw, taper, shaft and bore contact areas.

Therefore, it is important **not** to use Molybdenum Disulfide (e.g., Molykote, Never-Seize or similar lubricants) in any Keyless Bushing installation.

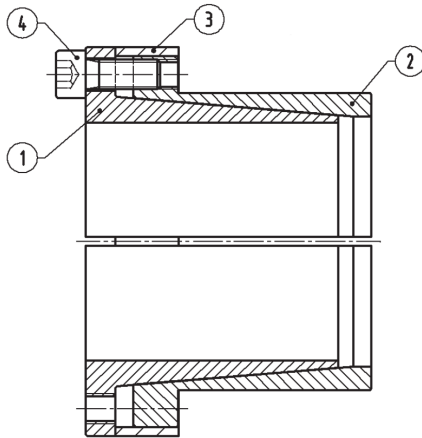

Figure 1

1. Make sure that locking screw, taper, shaft and bore contact areas are clean and lightly oiled with a light machine oil and that all collar slits are aligned.
2. Loosen all locking screws by a minimum of two (2) turns and transfer at least three (3) screws into push-off threads in order to keep Parts 1 and 2 separated during assembly (see Figure 2).
3. After inserting Keyless Bushing into hub bore, relocate locking screws used for separating Parts 1 and 2.
4. Hand tighten locking screws and confirm that collar Item 1 is parallel with face of part to be attached to shaft, and that spacer sleeve fully contacts both part and Keyless Bushing face.
5. Use torque wrench and set it approximately 5% higher than specified tightening torque ( $M_a$ ). Tighten locking screws in either a clockwise or counterclockwise sequence (it is not necessary to tighten in a diametrically opposite pattern), using only 1/4 (i.e., 90°) turns for several passes until 1/4 turns can no longer be achieved.
6. Continue to apply overtorque for 1 to 2 more passes. This is required to compensate for a system-related relaxation of locking screws since tightening of a given screw will always relax adjacent screws. Without overtorquing, an infinite number of passes would be needed to reach specified tightening torque.
7. Reset torque wrench to specified torque ( $M_a$ ) and check all locking screws. No screw should turn at this point, otherwise repeat Steps 6 and 7.

- NOTE:**
1. It is not necessary to re-check tightening torque after equipment has been in operation.
  2. In applications subject to extreme corrosion, the slits in all collars can be sealed with a suitable caulking compound or equivalent. Likewise, push-off threads should be protected from corrosion.

### INSTALLATION OF B-LOC® KEYLESS BUSHING OVER SHAFT KEYWAYS

The Keyless Bushing should be positioned so that slits in Keyless Bushing collars that contact the shaft are located approximately opposite the keyway. In addition, a locking screw should be centered directly over the keyway.

When tightening locking screws, it is important to follow the installation procedure outlined above, which specifies equal 1/4 turns of each locking screw. Failure to follow these instructions could result in excessive tightening of the screw over the keyway, possibly causing permanent deformation of the Keyless Bushing collars.

### REMOVAL (Refer to Figure 2)

**Prior to initiating the following removal procedure, check to ensure that no torque or thrust loads are acting on the Keyless Bushing, shaft or any mounted components.**

**IMPORTANT!** Make sure ends of locking screws used for removal are ground flat and are slightly chamfered to prevent damage to screw and collar threads during push-off.

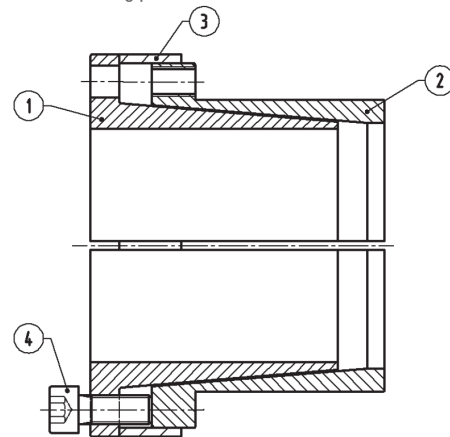

Figure 2

1. Check to ensure that axial movement of collars - necessary for release of connection - is not restricted. Likewise, ensure that push-off threads are in good condition.
2. Loosen locking screws in several stages by using approx. 1/4 turns, following either a clockwise or counterclockwise sequence. Transfer required number of screws into all push-off threads of clamp collar Item 1 (see Figure 2).
3. Release connection by evenly tightening all push-off screws (not exceeding 1/4 turns) in either a clockwise or counterclockwise sequence.

### Locking Screw Sizes and Specified Tightening Torque $M_a$

Metric Series	Inch Series	Tightening Torque $M_a$ (ft lb)	Screw Size	Hex Key Size (mm)
6 x 14 to 14 x 23	1/4 to 1/2	3.55	M4	3
15 x 24 to 42 x 55	5/8 to 1-5/8	12	M6	5
45 x 59 to 65 x 84	1-11/16 to 2-1/2	30	M8	6
70 x 90 to 95 x 120	2-5/8 to 3-3/4	60	M10	8
100 x 125 to 130 x 165	3-7/8 to 4-15/16	105	M12	10

**B-LOC Keyless Bushings provide a high capacity, zero-backlash shaft/hub or coupling connection by means of a mechanical interference fit. Please follow these INSTALLATION AND REMOVAL INSTRUCTIONS carefully to ensure proper performance of this B-LOC unit.**

### ⓘ WARNING ⓘ

When installing or removing B-LOC products, always adhere to the following safety standards:

1. Be sure that the system is de-energized using proper lockout/tagout procedures.
2. Wear proper personal protective equipment.

### INSTALLATION (Refer to Figure 1)

B-LOC Shrink Discs are supplied ready for installation. However, prior to tightening of locking screws it is necessary to remove wooden spacers that may have been used during shipping.

**IMPORTANT:** Never tighten locking screws before shaft installation, as inner ring of Shrink Disc and/or hub can be permanently contracted even at relatively low tightening torques.

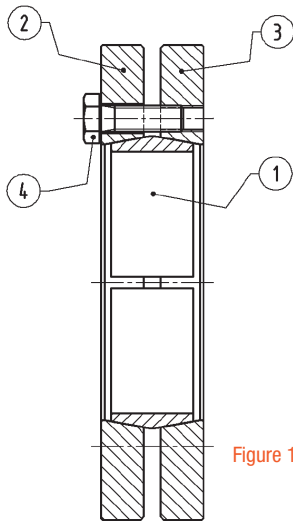

Figure 1

1. Clean hub O.D. and Shrink Disc bore. Lightly lubricate hub O.D. using an ordinary machine oil before assembling Shrink Disc on hub.
2. Carefully clean shaft and hub bore of any lubricant using a non-petroleum based solvent prior to mounting hub onto shaft. **This step is critical, as any lubricant on the shaft/hub bore interface will greatly reduce the torque transmitting capacity of a B-LOC Shrink Disc connection.**
3. After confirming correct position of hub and Shrink Disc, hand-tighten three (3) or four (4) equally spaced locking screws and make sure that outer collars of Shrink Disc are parallel. Hand-tighten remaining locking screws.
4. Use torque wrench and set it approximately 5% higher than specified tightening torque ( $M_a$ ). Tighten locking screws in either a clockwise or counterclockwise sequence, using approx. 1/4 (i.e., 90°) turns (even if initially some locking screws require a very low tightening torque to achieve 1/4 turns) for several passes until 1/4 turns can no longer be achieved.
5. Continue to apply overtorque for 1 to 2 more passes. This is required to compensate for a system-related relaxation of locking screws since tightening of a given screw will always relax adjacent screws. Without over torquing, an infinite number of passes would be needed to reach specified tightening torque.
6. Reset torque wrench to specified torque ( $M_a$ ) and check all locking screws. No screw should turn at this point, otherwise repeat Steps 5 and 6.

### REMOVAL (Refer to Figure 2)

**Prior to initiating the following removal procedure, check to ensure that no torque or thrust loads are acting on the Keyless Bushing, shaft or any mounted components.**

1. Loosen all locking screws in several stages by using approx. 1/2 (i.e., 180°) turns, following either a clockwise or counterclockwise sequence, until Shrink Disc can be moved on hub. The Shrink Disc, hub and shaft will return to their original clearance fits.

### ⓘ WARNING ⓘ

**DO NOT** completely remove locking screws before outer collars are disengaged from inner ring. A sudden release of the outer collars involves high separating forces and could result in permanent injury or death. Be certain that outer collars are disengaged from inner ring before completely removing locking screws.

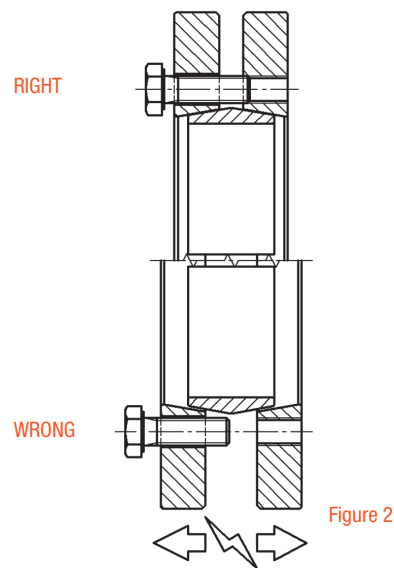

Figure 2

### REINSTALLATION OF SHRINK DISCS

In relatively clean operating conditions, Shrink Discs can be re-used without prior cleaning. Shrink Discs used under severe conditions, however, require thorough cleaning and re-lubrication with Dow Corning® Molykote® G-Rapid Plus Paste or equivalent.

#### Locking Screw Sizes and Specified Tightening Torque $M_a$

Screw Size	M5	M6	M8	M10	M12	M16	M20	M24	M27
Tightening Torque $M_a$ (ft lb)	3.6	8.7	22	44	74	185	362	620	922
Wrench Size Across Flats (mm)	8	10	13	17	19	24	30	36	41

**B-LOC Keyless Bushings provide a high capacity, zero-backlash shaft/hub or coupling connection by means of a mechanical interference fit. Please follow these INSTALLATION AND REMOVAL INSTRUCTIONS carefully to ensure proper performance of this B-LOC unit.**

### ⓘ WARNING ⓘ

When installing or removing B-LOC products, always adhere to the following safety standards:

1. Be sure that the system is de-energized using proper lockout/tagout procedures.
2. Wear proper personal protective equipment.

### INSTALLATION (Refer to Figure 1)

Remove B-LOC® Split Shrink Disc from protective wrapping and check to ensure tapered surfaces are coated with Molykote. Using Molykote G-Rapid Plus paste provided with the unit apply to screw threads and underside of screw head.

**IMPORTANT:** Never tighten locking screws before shaft installation, as inner ring of Split Shrink Disc and/or hub can be permanently contracted even at relatively low tightening torques.

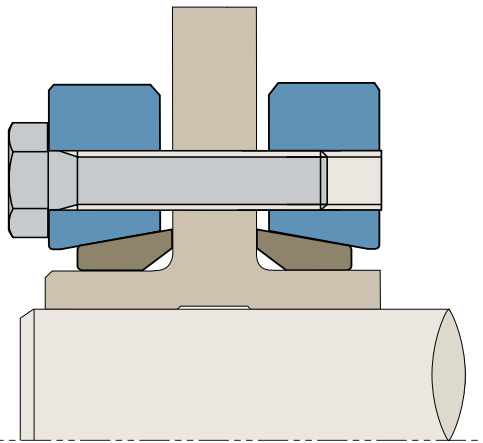

Figure 1

1. Clean hub O.D. and each Split Shrink Disc bore. Lightly lubricate hub O.D. using an ordinary machine oil before assembling Split Shrink Disc halves on hub.
2. Carefully clean shaft and hub bore of any lubricant using a non-petroleum based solvent prior to mounting hub onto shaft. **This step is critical, as any lubricant on the shaft/hub bore interface will greatly reduce the torque transmitting capacity of a B-LOC Split Shrink Disc connection.**
3. Slide each Split Shrink Disc half over the hub projection and align mounting holes as required. Insert the capscrews into the clearance holes of the outer ring and hub web; thread them into the tapped holes of the opposite outer ring.
4. After confirming correct position of hub and Split Shrink Disc, hand-tighten three (3) or four (4) equally spaced locking screws and make sure that outer rings of Split Shrink Disc are parallel or perpendicular to hub web or shaft respectively. Hand-tighten remaining locking screws.
5. Use torque wrench and set it approximately 5% higher than specified tightening torque ( $M_a$ ). Tighten locking screws in either a clockwise or counterclockwise sequence, using approx. 1/4 (i.e., 90°) turns (even if initially some locking screws require a very low tightening torque to achieve 1/4 turns) for several passes until 1/4 turns can no longer be achieved.
6. Continue to apply overtorque for 1 to 2 more passes. This is required to compensate for a system-related relaxation of locking screws since tightening of a given screw will always relax adjacent screws. Without over torquing, an infinite number of passes would be needed to reach specified tightening torque.
7. Reset torque wrench to specified torque ( $M_a$ ) and check all locking screws. No screw should turn at this point, otherwise repeat Step 5 and 6.

### REMOVAL (Refer to Figure 2)

**Prior to initiating the following removal procedure, check to ensure that no torque or thrust loads are acting on the Keyless Bushing, shaft or any mounted components.**

1. Loosen all locking screws in several stages by using approx. 1/2 (i.e., 180°) turns, following either a clockwise or counterclockwise sequence, until Split Shrink Disc can be moved on hub. The Split Shrink Disc, hub and shaft will return to their original clearance fits.

### ⓘ WARNING ⓘ

**DO NOT** completely remove locking screws before outer collars are disengaged from inner ring. A sudden release of the outer collars involves high separating forces and could result in permanent injury or death. Be certain that outer collars are disengaged from inner ring before completely removing locking screws.

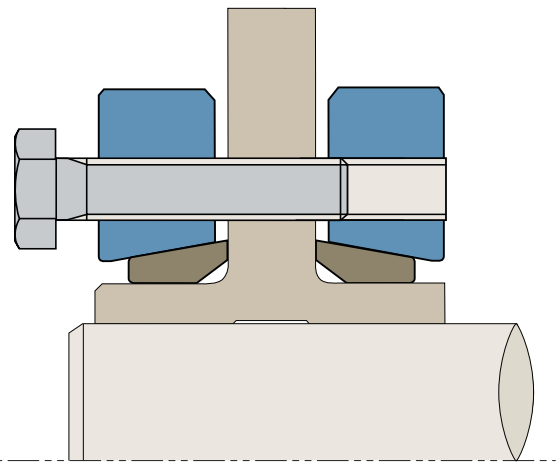

Figure 2

### REINSTALLATION OF SHRINK DISCS

In relatively clean operating conditions, Shrink Discs can be re-used without prior cleaning. Shrink Discs used under severe conditions, however, require thorough cleaning and re-lubrication with Dow Corning® Molykote® G-Rapid Plus Paste or equivalent.

#### Locking Screw Sizes and Specified Tightening Torque $M_a$

Screw Size	M5	M6	M8	M10	M12	M16	M20	M24	M27
Tightening Torque $M_a$ (ft lb)	3.6	8.7	22	44	74	185	362	620	922
Wrench Size Across Flats (mm)	8	10	13	17	19	24	30	36	41

# Installation & Removal Instructions for B-LOC®

## Half Shrink Discs Type HC & HT

# B-LOC®

B-LOC Keyless Bushings provide a high capacity, zero-backlash shaft/hub or coupling connection by means of a mechanical interference fit. Please follow these **INSTALLATION AND REMOVAL INSTRUCTIONS** carefully to ensure proper performance of this B-LOC unit.

### ⓘ WARNING ⓘ

When installing or removing B-LOC products, always adhere to the following safety standards:

1. Be sure that the system is de-energized using proper lockout/tagout procedures.
2. Wear proper personal protective equipment.

### INSTALLATION (Refer to Figure 1)

Remove B-LOC® Half Shrink Disc from protective wrapping and check to ensure tapered surfaces are coated with Molykote. Using Molykote G-Rapid Plus paste provided with the unit apply to screw threads and underside of screw head.

**IMPORTANT:** Never tighten locking screws before shaft installation, as inner ring of Half Shrink Disc and/or hub can be permanently contracted even at relatively low tightening torques.

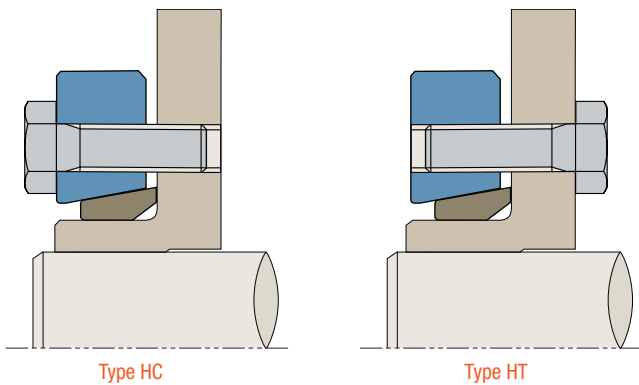

Figure 1

1. Clean hub O.D. and Half Shrink Disc bore. Lightly lubricate hub O.D. using an ordinary machine oil before assembling Half Shrink Disc on hub.
2. Carefully clean shaft and hub bore of any lubricant using a non-petroleum based solvent prior to mounting hub onto shaft. This step is critical, as any lubricant on the shaft/hub bore interface will greatly reduce the torque transmitting capacity of a B-LOC Half Shrink Disc connection.
3. Slide Half Shrink Disc over the hub projection and align mounting holes as required. For Half Shrink Disc Type HC: insert the capscrews into the clearance holes of the outer ring and thread them into the tapped holes of the mating web. For Half Shrink Disc Type HT: insert the capscrews through the mating web clearance holes and thread into tapped holes of outer ring.
4. After confirming correct position of hub and Half Shrink Disc, hand-tighten three (3) or four (4) equally spaced locking screws and make sure that outer ring of Half Shrink Disc is parallel or perpendicular to hub web or shaft respectively. Hand-tighten remaining locking screws.
5. Use torque wrench and set it approximately 5% higher than specified tightening torque ( $M_a$ ). Tighten locking screws in either a clockwise or counterclockwise sequence, using approx. 1/4 (i.e., 90°) turns (even if initially some locking screws require a very low tightening torque to achieve 1/4 turns) for several passes until 1/4 turns can no longer be achieved.
6. Continue to apply overtorque for 1 to 2 more passes. This is required to compensate for a system-related relaxation of locking screws since tightening of a given screw will always relax adjacent screws. Without over torquing, an infinite number of passes would be needed to reach specified tightening torque.
7. Reset torque wrench to specified torque ( $M_a$ ) and check all locking screws. No screw should turn at this point, otherwise repeat Step 5 and 6.

### REMOVAL (Refer to Figure 2)

**Prior to initiating the following removal procedure, check to ensure that no torque or thrust loads are acting on the Keyless Bushing, shaft or any mounted components.**

1. Loosen all locking screws in several stages by using approx. 1/2 (i.e., 180°) turns, following either a clockwise or counterclockwise sequence, until Half Shrink Disc can be moved on hub. The Half Shrink Disc, hub and shaft will return to their original clearance fits.

### ⓘ WARNING ⓘ

**DO NOT** completely remove locking screws before outer collars are disengaged from inner ring. A sudden release of the outer collars involves high separating forces and could result in permanent injury or death. Be certain that outer collars are disengaged from inner ring before completely removing locking screws.

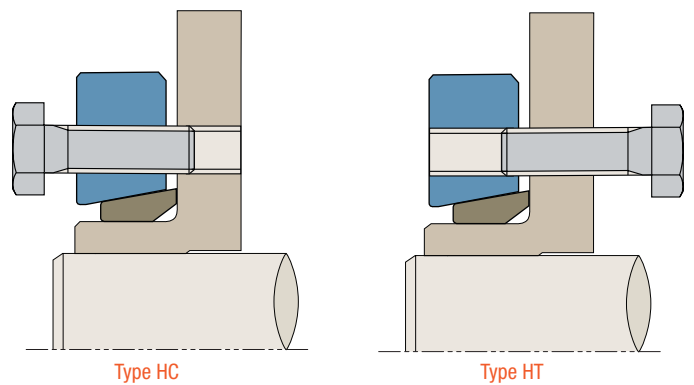

Figure 2

### REINSTALLATION OF SHRINK DISCS

In relatively clean operating conditions, Shrink Discs can be re-used without prior cleaning. Shrink Discs used under severe conditions, however, require thorough cleaning and re-lubrication with Dow Corning® Molykote® G-Rapid Plus Paste or equivalent.

#### Locking Screw Sizes and Specified Tightening Torque $M_a$

Screw Size	M5	M6	M8	M10	M12	M16	M20	M24	M27
Tightening Torque $M_a$ (ft lb)	3.6	8.7	22	44	74	185	362	620	922
Wrench Size Across Flats (mm)	8	10	13	17	19	24	30	36	41

# Installation & Removal Instructions for B-LOC®

## Shrink Discs Series SD40

# B-LOC®

B-LOC Keyless Bushings provide a high capacity, zero-backlash shaft/hub or coupling connection by means of a mechanical interference fit. Please follow these **INSTALLATION AND REMOVAL INSTRUCTIONS** carefully to ensure proper performance of this B-LOC unit.

### ⓘ WARNING ⓘ

When installing or removing B-LOC products, always adhere to the following safety standards:

1. Be sure that the system is de-energized using proper lockout/tagout procedures.
2. Wear proper personal protective equipment.

### INSTALLATION (Refer to Figure 1)

B-LOC SD40 Shrink Discs are supplied ready for installation. Therefore do not disassemble the unit.

**IMPORTANT:** Never tighten locking screws before shaft installation, as inner ring of Shrink Disc and/or hub can be permanently contracted even at relatively low tightening torques.

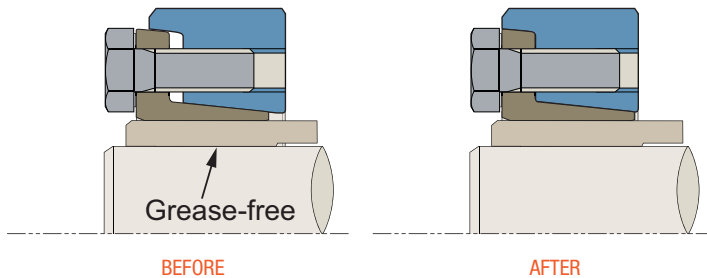

Figure 1

1. Clean hub O.D. and Shrink Disc bore. Lightly lubricate hub O.D. using ordinary machine oil before assembling Shrink Disc on hub.
2. Carefully clean shaft and hub bore of any lubricant using a non-petroleum-based solvent prior to mounting hub onto shaft. This step is critical, as any lubricant on the shaft/hub bore interface will greatly reduce the torque transmitting capacity of a B-LOC® SD40 Shrink Disc connection.
3. After confirming correct position of hub and Shrink Disc, hand-tighten three (3) or four (4) equally spaced locking screws making sure that inner and outer ring are parallel. Hand-tighten remaining locking screws.

### INSTALLATION WITH A TORQUE WRENCH

4. Use torque wrench and set it approximately 5% higher than specified tightening torque ( $M_a$ ). Tighten locking screws in either a clockwise or counterclockwise sequence, using approx. 1/4 (i.e., 90°) turns (even if initially some locking screws require a very low tightening torque to achieve 1/4 turns) for several passes until 1/4 turns can no longer be achieved.
5. Continue to apply overtorque for 1 to 2 more passes. This is required to compensate for a system-related relaxation of locking screws since tightening of a given screw will always relax adjacent screws. Without over torquing, an infinite number of passes would be needed to reach specified tightening torque.
6. Reset torque wrench to specified torque ( $M_a$ ) and check all locking screws. No screw should turn at this point, otherwise repeat Steps 5 and 6.

### INSTALLATION WITHOUT A TORQUE WRENCH

7. Tighten locking screws in either a clockwise or counterclockwise sequence, using approx. 1/4 (i.e., 90°) turns for several passes until the faces of the outer ring and inner ring are aligned flush. (See Figure 1 - After)

### REMOVAL (Refer to Figure 2)

**Prior to initiating the following removal procedure, check to ensure that no torque or thrust loads are acting on the Shrink Disc, shaft or any mounted components.**

1. Loosen all locking screws in several stages by using approx. 1/2 (i.e., 180°) turns, following either a clockwise or counterclockwise sequence, until Shrink Disc can be moved on hub. If the shrink disc does not release, transfer the appropriate number of screws into the threaded backoff holes in the outer ring (Figure 2). Evenly and progressively tighten these screws, in either a clockwise or counter clockwise sequence, until outer ring releases. The shrink disc, hub and shaft will return to their original clearance fits.

### IMPORTANT:

Prior to removal the ends of push off screws are to be ground flat and chamfered to prevent damage to screw and outer ring threads during backoff.

### ⓘ WARNING ⓘ

**DO NOT** completely remove locking screws before outer collars are disengaged from inner ring. A sudden release of the outer collars involves high separating forces and could result in permanent injury or death. Be certain that outer collars are disengaged from inner ring before completely removing locking screws.

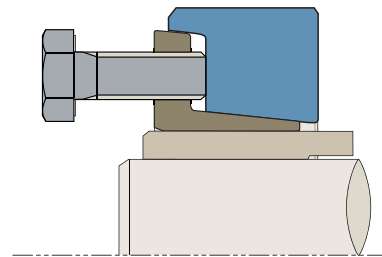

Figure 2

### REINSTALLATION OF SHRINK DISCS

In relatively clean operating conditions, Shrink Discs can be re-used without prior cleaning. Shrink Discs used under severe conditions, however, require thorough cleaning and re-lubrication with Dow Corning® Molykote® G-Rapid Plus Paste or equivalent.

### Locking Screw Sizes and Specified Tightening Torque $M_a$

Screw Size	M8	M10	M12	M14	M16	M20	M24	M27	M30
Tightening Torque $M_a$ (ft lb)	25	52	89	140	214	420	730	1092	1460
Wrench Size Across Flats (mm)	13	17	19	21	24	30	36	41	46

# Installation & Removal Instructions for B-LOC®

## Compression Hub Series BCH20 & BCH50

# B-LOC®

B-LOC Keyless Bushings provide a high capacity, zero-backlash shaft/hub or coupling connection by means of a mechanical interference fit. Please follow these **INSTALLATION AND REMOVAL INSTRUCTIONS** carefully to ensure proper performance of this B-LOC unit.

### ⓘ WARNING ⓘ

When installing or removing B-LOC products, always adhere to the following safety standards:

1. Be sure that the system is de-energized using proper lockout/tagout procedures.
2. Wear proper personal protective equipment.

### INSTALLATION (Refer to Figure 1 and 2)

B-LOC Keyless Locking Devices are supplied lightly oiled and ready for installation. The frictional torque capacity of these devices is based on a particular coefficient of friction resulting from lightly oiled tapers, shaft and bore contact areas. Therefore, it is important to not use Molybdenum Disulfide (or similar lubricants) on any of the BLOC components.

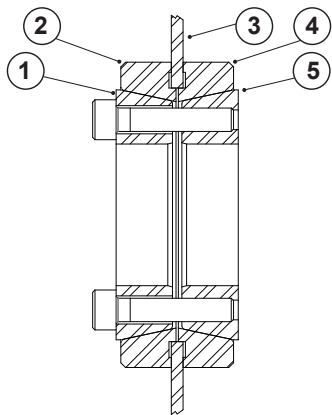

Figure 1

1. Make sure that the locking device, taper, shaft and hub contact areas are clean and lightly oiled.
2. Loosen and remove all locking screws
3. Grasping the front outer ring item 2, lift the front outer ring and front inner ring off the assembly (items 1 and 2).
4. Add the hub plate (item 3) to the assembly by aligning the bore of the hub plate with the pilot surface of the rear outer ring (item 4). This should be a close clearance fit, so care should be taken to ensure alignment.
5. Place the front outer ring (item 2) and front inner ring (item 1) on the assembly by aligning the hub plate bore with the pilot surface.
6. Rotate the front inner ring (item 1) until the slit is aligned with the slit in the rear inner ring item 5, then insert the locking screws thru the clearance holes in the front inner ring (item 1).
7. Thread the screws into the corresponding holes in the rear inner ring (item 5). Hand-tighten each screw, and confirm that the faces of the hub plate (item 3) are flush with the contacting face of the outer rings (items 2 and 4).
8. Set a torque wrench to approximately 5% higher than the specified installation torque  $M_a$ . Using only  $\frac{1}{4}$  (i.e.,  $90^\circ$ ) turns, tighten locking screws in either a clockwise or counterclockwise sequence (a diametrically opposite pattern can also be used, but is not required). Continue the tightening sequence until the torque wrench clicks on each screw before  $\frac{1}{4}$  turns can be achieved.
9. Continue to apply 5%-overtorque for one to two more passes. This is required to compensate for a system-related relaxation of locking screws since tightening of a given screw will always relax adjacent screws. (Without the 5% overtorque, an infinite number of passes would be needed to reach the specified installation torque.)
10. Reset torque wrench to specified torque ( $M_a$ ) and check all locking screws. No screw should turn at this point. Otherwise, repeat Steps 9 and 10.

### INSTALLATION OF B-LOC® KEYLESS BUSHING OVER SHAFT KEYWAYS

The Keyless Locking Device should be positioned so that slits in Keyless Locking Device collars that contact the shaft are located approximately opposite the keyway. In addition, a locking screw should be centered directly over the keyway.

When tightening locking screws, it is important to follow the installation procedure outlined above, which specifies equal  $\frac{1}{4}$  turns of each locking screw. Failure to follow these instructions could result in excessive tightening of the screw over the keyway, possibly causing permanent deformation of the Keyless Locking Device collars.

### REMOVAL (Refer to Figure 2)

**Prior to initiating the following removal procedure, check to ensure that no torque or thrust loads are acting on the Shrink Disc, shaft or any mounted components.**

**IMPORTANT!** Make sure ends of locking screws used for removal are ground flat and are slightly chamfered to prevent damage to screw and collar threads during push-off.

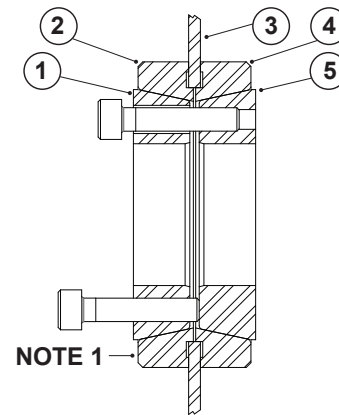

Figure 2

1. Check to ensure that axial movement of clamp collars and hub plate (necessary for release of connection) are not restricted. Likewise, ensure that push-off threads are in good condition.
2. Loosen all locking screws in sequence by  $\frac{1}{4}$  turns until screws can be turned by hand. Loosen by hand for several more turns.
3. Remove completely two locking screws approximately 180 degrees apart. **IMPORTANT!** All other locking screws should be left in place.
4. Grind a chamfer on the ends of the two screws. Transfer these screws into the push-off threads of front inner ring (item 1) (see Figure 2).
5. Release the assembly by progressively tightening the two push-off screws using  $\frac{1}{4}$  turns. Typically, the push-off screws appear to be completely tight after just one pass of tightening without any noticeable separation of clamp collars. Although it seems that the screws cannot be tightened further, several more rounds of torquing will increase the push-off force in the system and ultimately release the tapers.

### NOTES:

- 1: If the tapers do not release after the assembly is jacked apart for several revolutions of the push-off screws, a brass punch or similar tool can be used to exert an impact force on the front outer ring (item 2).
- 2: In installations subjected to extreme corrosion, the slits in clamp collars (items 1 and 5) should be sealed with a suitable caulking compound or sealant. Likewise, push-off threads should also be protected from corrosion.

### Locking Screw Sizes and Specified Tightening Torque $M_a$

Screw Size	M4	M5	M6	M8	M10
Tightening Torque $M_a$ (ft lb)	25	52	89	140	214
Wrench Size Across Flats (mm)	13	17	19	21	24

# Installation & Removal Instructions for B-LOC®

## WK Rigid Coupling

# B-LOC®

Please follow these **INSTALLATION AND REMOVAL INSTRUCTIONS** carefully to ensure proper performance of this B-LOC unit.

### ⓘ WARNING ⓘ

When installing or removing B-LOC products, always adhere to the following safety standards:

1. Be sure that the system is de-energized using proper lockout/tagout procedures.
2. Wear proper personal protective equipment.

### INSTALLATION (Refer to Figure 1)

B-LOC WK Rigid Couplings are supplied ready for installation. For increased torque transmission, see Special Considerations.

**IMPORTANT!** Never tighten locking screws before shaft installation, as the WK Rigid Coupling inner ring (3) can be permanently deformed even at relatively low tightening torques.

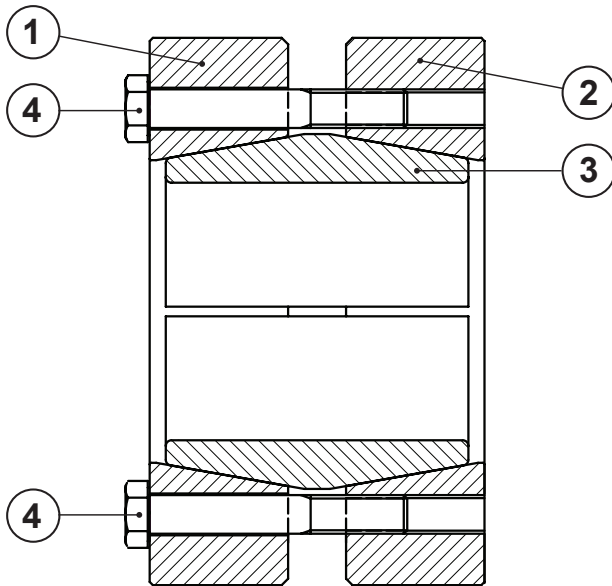

Figure 1

1. Using a non-petroleum based solvent, carefully clean shafts of any lubricants prior to mounting coupling on shafts. **This step is critical, as any contaminants on the shafts may alter the performance of a B-LOC WK Rigid Coupling connection.**
2. Center coupling over shaft ends. Hand-tighten three or four equally spaced locking screws (4) assuring outer collars (1, 2) of WK Rigid Coupling are parallel. Hand-tighten remaining locking screws.
3. Use a torque wrench set to the overtorque valued listed in the chart. This value is ~5% higher than specified install torque, (Ma). Tighten locking screws in either a clockwise or counterclockwise sequence, using approximately 1/4 (i.e., 90°) turns (even if initially some locking screws require a very low tightening torque to achieve 1/4 turns) for several passes until 1/4 turns can no longer be achieved.
4. Continue to apply overtorque for one to two more passes. This is required to compensate for a system-related relaxation of locking screws since tightening of a given screw will always relax adjacent screws. Without overtorquing, an infinite number of passes would be needed to reach specified install torque.
5. Reset torque wrench to specified install torque (Ma) and check all locking screws. No screw should turn at this point, otherwise repeat Steps 4 and 5.

### REMOVAL (Refer to Figure 1)

### ⓘ WARNING ⓘ

Prior to initiating the following removal procedure, check to ensure that no torque or thrust loads are acting on the WK Rigid Coupling, shaft or any mounted components.

Loosen all locking screws in several stages by using approximately 1/2 turns, following either a clockwise or counterclockwise sequence, until the WK Rigid Coupling can be moved on the shafts. The WK Rigid Coupling will return to its original clearance fit.

### ⓘ WARNING ⓘ

**DO NOT** completely remove locking screws (4) before outer collars (1, 2) are disengaged from inner ring (3). A sudden release of the outer collars involves high separating forces and could result in permanent injury or death. Be certain that outer collars are disengaged from inner ring before completely removing locking screws. Refer to Figure 1.

### REINSTALLATION OF WK RIGID COUPLINGS

In relatively clean operating conditions, WK Rigid Couplings can be reused without prior cleaning. WK Rigid Couplings used under severe conditions, however, require thorough cleaning. Relubricate screws and tapers with Dow Corning® Molykote® G-n Metal Assembly Paste or equivalent. Lightly coat the remainder of the unit with standard machining oil. Upon doing so, install following INSTALLATION portion of this document.

### SPECIAL CONSIDERATION

If your application requires increased torque transmission and/or thrust, in addition to using a non-petroleum based solvent to clean the shafts (as stated in step 1), the bore of the WK Rigid Coupling needs to be cleaned with a non-petroleum based solvent to produce an oil free connection. This in turn will result in up to a 20% increase in Mt and Th performance values.

Screw Type	Locking Screw Sizes and Specified Tightening Torque Ma			
	M6	M8	M10	M12
Overtorque (ft lb)	9.1	23	46	78
Install Torque (ft lb)	8.7	22	44	74
Wrench Size Across Flats (mm)	10	13	16	18

**These Screw Sizes Are Installed on the Following WK Series:**

- M6 - WK 15, 20, 25, 30
- M8 - WK 40, 50, 60
- M10 - WK 70
- M12 - WK 80, 90, 100, 120